

ATTENTION

PLEASE READ THIS INFORMATION BEFORE OPERATION!

Driver- and analyzation board for SENSORE oxygen sensors

Technical data:

- Applicable to all offered sensor types
- Micro processor controlled
- Temperature control of sensor element (no influence of the ambient medium temperature onto output signal)
- Linearized output signal for all sensor types 0 – 5 V DC (lower output voltage adjustable with the optional software)
- 4 programmable threshold values for alarm (programmable with the optional software)
- Serial interface
- Adjustment of the electronic (Calibration of the sensor, measuring of the heater resistance) with jumper
- Input voltage 7-30 VDC or 6 VDC (optional)
- Power consumption about 2.5 – 3.0 Watts
- Cable length to the sensor up to 10 meters
- PCB size: 120 * 100 mm
- Optional software for reading and storing measurement data and adjustment of the electronic available

Sketch of the electronic board with all connector- and jumper blocks:

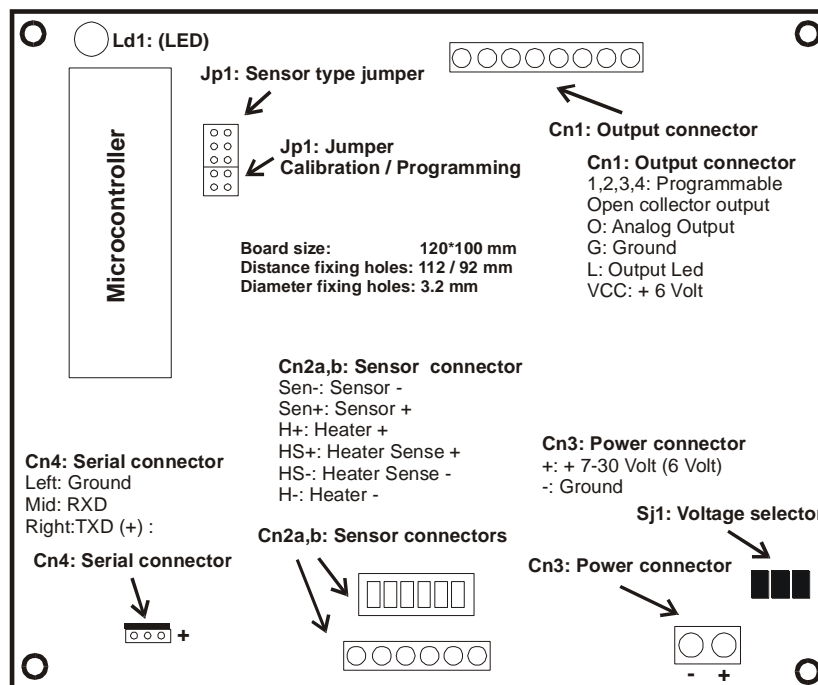

The information contained in this document is believed to be accurate and reliable but is presented without guarantee.

Initial operation:

Attention: During initial operation or during operation never place the conducting Antistatic packing below the electronic board!

During initial operation following items have to be performed:

1. Connect the sensor to the electronic board
2. Set the used sensor type
3. Prepare for measure the sensor heater resistance
4. Connect the power supply
5. Measure the sensor heater resistance
6. Calibrate the sensor

Attention: It is not possible to start sensor operation if jumper Pgm (jumper block Jp1) is shorted!

Connect the sensor to the electronic board (Cn2A or Cn2B)

Depending on the sensor type the sensor has to be connected to block Cn2A (sensor without connection plug) or block Cn2B (sensor with a connection plug). During operation with the electronic board it is necessary to use 6 wires due to the measuring system of the heater resistance (4-wire system). Therefore the heater has to be connected with 4 wires according to the sketch below:

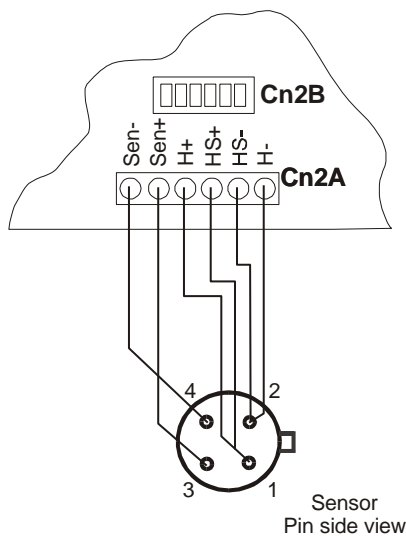

Attention: It is absolutely necessary to connect 4 wires to the sensor heater!!!

If the sensor is supplied with connection wires, please connect as follows:

OR

Black	Sen-	Black.....	Sen-
Red	Sen+	Red.....	Sen+
White 1.....	H+	White	H+
White 2.....	HS+	Yellow	HS+
Violet 1.....	HS-	Green	HS-
Violet 2.....	H-	Blue	H-

Set the used sensor type via jumper Jp1

The used sensor type has to be set via jumper block Jp1 (see sketch for jumper position). For this set only the measuring range of the sensor is important (not the type of housing). The default adjustment is the sensor with measuring range 0.1 – 25%.

Typ	1	2	3	Max. O2
SO-XX-000	1	1	1	200 ppm
SO-XX-001	0	1	1	1000 ppm
SO-XX-010	1	0	1	1 %
SO-XX-020	0	0	1	2 %
SO-XX-050	1	1	0	5 %
SO-XX-250	0	1	0	25%
SO-XX-960	1	0	0	96%

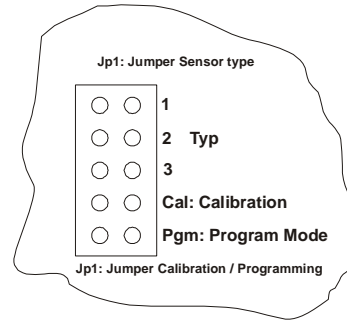

(1 .. jumper shorted, 0 .. no jumper)

Prepare for measure sensor heater resistance

For initial operation the cold resistance of the sensor heater has to be measured once. For that jumper Cal (Jp1) has to be set before connecting the input voltage (see sketch at point 2 for jumper position).

Connect the power supply (Cn3)

The input voltage has to be connected to connector block Cn3. (see sketch for connector position)

+	7-30V	+7-30 volts
-	GND	Ground

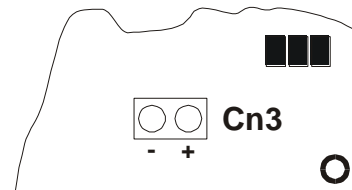

After connection of the power supply the electronic starts a self test immediately. During this test all outputs (red LED for displaying operation conditions and all threshold outputs) will be activated for one second. Additionally the analog output will have 5 volts for one second.

Measure the heater resistance

After connecting the input voltage and a delay time of 5 seconds the jumper must be removed. The heater resistance is measured and stored already.

After removing the jumper the heating up process of the sensor starts immediately. This will be displayed by a blinking red operation LED (2.5 sec off / 0.5 sec on). Once operation temperature is reached the red LED is lightened constant. If there is any problem with the sensor heater, the LED starts flashing slowly (2 sec off / 2 sec on).

Calibrate the sensor

To get correct output values the sensor has to be calibrated once. For that an at least 5 minute operation is recommended to ensure the temperature stability of the unit.

For calibration the sensor has to be in an environment of known oxygen concentration. The required oxygen concentrations for calibration are listed below. For sensor types SO-XX-250 and SO-XX-960 surrounding air can be used as calibration gas. In that case the sensor should be operated in a well ventilated area.

Calibration of the electronic is done by setting the jumper Cal for some seconds during operation. Hereby the output of the board is set to a default value by means of a sensor type dependent calibration factor.

After these initial calibration and measurement procedures the electronic is ready for measurement.

Attention: All procedures above has to be done only once respectively only after changing the sensor!

If the measuring signal exceeds the measuring range during normal operation, the red LED flashes fast (0.5 sec off / 0.5 sec on).

Summary of all signals of the operation LED

Indication	Condition
LED is lightening	Normal operation
LED flashes fast (0.5 sec off / 0.5 sec on)	Measuring value exceeds measuring range
LED flashes irregular (2.5 sec off / 0.5 sec on)	Heating up process has started
LED flashes slow (2.0 sec off / 2.0 sec on)	Sensor heater error

Description of available connector and jumper blocks

Jn1: Output connector

4	Threshold output 4
3	Threshold output 3
2	Threshold output 2
1	Threshold output 1
O	Analog output
G	Ground
L	Output for Sensor ready LED
VCC	+ 6 Volts

Cn2A: Sensor connector

HS+	Heater sense +
HS-	Heater sense -
S+	Sensor +
S-	Sensor -
H+	Heater +
H-	Heater -

Jn3: Power connector

		NC
+	7-30 V	+7-30 Volt
-	GND	Ground

Cn4: Serial connector

Left pin	GND
Mid pin	RXD
Right pin (+)	TXD

Jp1: Jumper block for setting sensor type and board calibration

Jumper 1,2,3 Selection of sensor type according following table

Typ	Jp1/1	Jp1/2	Jp1/3	Max. O2
SO-XX-000	1	1	1	200 ppm
SO-XX-001	0	1	1	1000 ppm
SO-XX-010	1	0	1	1 %
SO-XX-020	0	0	1	2 %
SO-XX-050	1	1	0	5 %
SO-XX-250	0	1	0	25%
SO-XX-960	1	0	0	96%

(1 .. Jumper shorted, 0 .. No jumper)

Cal	Resistance measurement and sensor calibration
Pgm	Programming EDAB-M1

Appendix

Table of default sensor parameters

Sensortyp	Sensor-voltage	Dig. Output value (Digout)	Output voltage (Uout)	At oxygen-concentration	k1 O2=k1*Digout	k2 O2=k2*Uout	Calibration-concentration
SO-xx-000	0.70 volts	1000	5.00 volts	200 ppm	0.200	40	200 ppm
SO-xx-001	0.70 volts	1000	5.00 volts	1000 ppm	1.000	200	1000 ppm
SO-xx-010	0.75 volts	1000	5.00 volts	1.0 %	0.001	0,2	1.00 %
SO-xx-020	0.75 volts	1000	5.00 volts	2.0 %	0.002	4	2.00 %
SO-xx-050	0.80 volts	1000	5.00 volts	5.0 %	0.005	1	5.00 %
SO-xx-250	0.85 volts	836	4.18 volts	20,%	0.025	5	20.9 %
SO-xx-960	1.60 volts	209	1.05 volts	20.9 %	0.100	20	20.9 %

Analog output and threshold outputs

The output range of the analog output is 0 – 5 Volts. The analog output provides 5 volts always (except the sensor type SO-XX-960) at the upper limit of measuring range of the used sensor (see also table above).

$$O_2[\%, ppm] = k_1 * DigOut = k_2 * Uout$$

The four threshold outputs drives a transistor (open collector), that switches through in case of exceeding or falling short a programmable oxygen concentration.

Serial data transfer

The actual measured value (and all appearing errors and special conditions is also available at the serial interface with a signal rate set by default.

Each value of 4 ASCII characters is followed by a carriage return:

D0	D1	D2	D3	CR
----	----	----	----	----

Characters set in a row give the digital output value (conversion see table above) that can be used for further calculations.

If serial output of errors and special conditions is activated (default), these conditions are available on the serial port too. The meanings of all codes are listed below (*1):

1010	Heating up process has started
1011	Sensor heater error
1013	Measuring value exceeds measuring range

Adjustments for the serial port: baud rate 19200, 8 data bits, no parity

Software for reading the measuring data via serial port and for adjustment of the electronic (option)

Sensore offers software to transfer and store the measuring data via serial port to a PC. Beside it is possible to adjust several parameters such as maximum output voltage, concentration of the calibration gas, concentration of the threshold outputs, of the electronic.